

# INSTALLATION, OPERATING and MAINTENANCE INSTRUCTIONS

## AERMOTOR WINDMILL CO. INC.

1-800-854-1656  
 PHONE 325 / 651-4951  
 FAX 325 / 651-4948  
 P.O. BOX 5110  
 SAN ANGELO, TEXAS U.S.A. 76902

MONDAY through FRIDAY  
 8AM - 5PM C.S.T.

### INDEX OF CONTENTS

Page

Windmill Specifications . . . . .	2
Assembly of Stub Tower . . . . .	3
Assembly of Sail Sections . . . . .	4
Assembling the Windmill . . . . .	5
Changing Mill to Short Stroke . . . . .	11
Oiling and Care of Windmill . . . . .	12
Replacement of Hub and Shaft . . . . .	13
Replacement of 752 Bearing . . . . .	14
Replacement of 523 Guide Wheel . . . . .	14
Problems - Cause - Remedy . . . . .	15
Windmill Maintenance Program . . . . .	16
Engineering Data . . . . .	21

### OWNER'S RECORD

WINDMILL SIZE 6, 8, 10, 12, 14, 16,  
(Circle the size)

DATE CODE \_\_\_\_\_

DATE OF INSTALLATION \_\_\_\_\_

DEPTH TO CYLINDER \_\_\_\_\_

SIZE OF CYLINDER \_\_\_\_\_

DROP PIPE SIZE \_\_\_\_\_

PUMP ROD SIZE \_\_\_\_\_

OWNER \_\_\_\_\_

INSTALLER \_\_\_\_\_

It is important to use a tower high enough for good wind exposure from every direction. The mill will pump more often, and will be safer in storms. The wheel should be at least 15 feet above all surrounding wind obstructions, such as buildings and trees, within a radius of 400 feet.

Please read thoroughly these instructions BEFORE attempting to install your AERMOTOR WINDMILL. It can not only save you time but also enable you to get the maximum performance from your windmill.

# HOW TO INSTALL THE AERMOTOR WINDMILL

## General Information and Precautions

It is recommended that there be at least two men, working together on the installation, to save time and make the job easier and safer.

As in any installation of this type, safety is extremely important. If proper safety measures are not taken, it can result in severe physical impairment, or even loss of life, not only to the workers but to innocent bystanders as well.

WE STRONGLY RECOMMEND THAT THE FOLLOWING SAFETY PRECAUTIONS BE TAKEN FOR THE PERSONAL SAFETY OF EACH WORKER AND THE SAFETY OF ANYONE NEAR THE TOWER WHILE WORK IS IN PROGRESS:

1. Wear approved (construction type) hard hats.
2. Wear and use approved safety belts.
3. Wear safety shoes having steel toes and rubber or cork soles and heels.

4. Avoid wearing loose-fitting or torn clothing which might snag on a steel member of the tower.
5. Be certain that shovels, iron bars and tools are located a distance away from the tower when they are not in use.
6. Be certain that all bolts and nuts are secure at each level of tower construction before standing or climbing on that section.
7. Make certain that there are no overhead electrical lines nearby that could come into contact with tower or windmill.

When these safety precautions have been taken, you are now ready to begin the assembly and installation of your windmill.

## AERMOTOR WINDMILL SPECIFICATIONS

Model 802*	Mill Size Wheel Dia. (Ft.)	Stroke Inches		No. Of Sails	Mill Ship'g Weight (Pounds)	Back Geared	Max. Strokes Per Minute	At Wind Velocity	Max. Wheel RPM	Weight Of Crated Motor
		Long	Short							
X	6	5"	3 <sup>3</sup> / <sub>4</sub> "	18	210	3.91-1	32	15-18 mph	125	100
A	8	7 <sup>1</sup> / <sub>8</sub> "	5 <sup>1</sup> / <sub>2</sub> "	18	355	3.29-1	32	15-18 mph	105	175
B	10	9 <sup>1</sup> / <sub>4</sub> "	7 <sup>1</sup> / <sub>4</sub> "	18	655	3.29-1	26	15-18 mph	85	330
D	12	11 <sup>1</sup> / <sub>4</sub> "	8 <sup>1</sup> / <sub>4</sub> "	18	1130	3.50-1	21	18-20 mph	73	540
E	14	13 <sup>1</sup> / <sub>2</sub> "	9 <sup>3</sup> / <sub>4</sub> "	18	1870	3.43-1	18	18-20 mph	62	805
F	16	14 <sup>7</sup> / <sub>8</sub> "	11 <sup>3</sup> / <sub>8</sub> "	18	2585	3.29-1	16	18-20 mph	53	1180

\*Model 802 Windmills were introduced in 1981 and parts are interchangeable with Model 702 Windmills introduced in 1933.

# Methods of Assembling

Your Aermotor windmill can be built complete on the ground and hoisted into place by means of a crane, boom truck or similar equipment.

It can also be assembled on the tower.

The method selected will depend largely upon the experience of the installer, his equipment and the size of mill.

A gin pole, block and tackle for hoisting mill into position is satisfactory for the smaller sizes of mills. A boom truck or crane will be necessary on the larger sizes of mills.

## TOWER REQUIREMENTS

1. AN AERMOTOR WINDMILL MAY BE MOUNTED ON ANY OTHER MAKE OF STEEL TOWER OR A WOOD TOWER BY USING AN AERMOTOR STUB TOWER.
2. NO STUB TOWER IS NEEDED FOR MOUNTING AERMOTOR ON AN AERMOTOR TOWER.
3. BE SURE THE TOWER IS ADEQUATE IN STRENGTH FOR THE SIZE OF MILL BEING ERECTED.

## ASSEMBLY OF STUB TOWER

1. Assemble the stub on the mill mast pipe and tighten all clamps and bolts.
2. Measure the width of the stub four inches above the bottom, if it is to go on steel tower, or six inches above the bottom for wood tower, and saw off the old tower at the point where it is the same width.
3. Slip the stub over the top of the old tower, plumb it very carefully so that the mill pipe will stand exactly vertical, and then mark and drill the holes for the bolts. Use four bolts in each corner. Figure 1 shows how the stub goes on either steel or wood tower.

DIMENSIONS AT BASE OF STUB TOWER					
MILL SIZE	6 & 8 Ft.	10 Ft.	12 Ft.	14 Ft.	16 Ft.
Stub Height					
*3 Feet	9½"	10"	—	—	—
4 Feet	11½"	—	13¼"	13¾"	—
5 Feet	—	14½"	—	—	16½"
7 Feet	19"	19"	20¼"	20¾"	21⅝"
14 Feet	35"	—	—	—	—

\*These stubs do not have a platform.  
For diagonal distance, multiply above by 1.414.

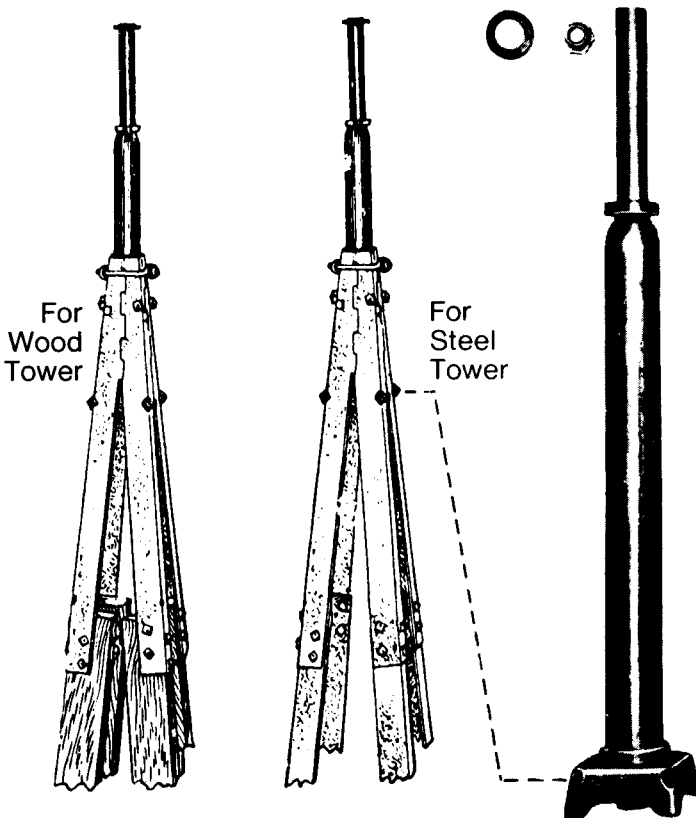

CAUTION: BEFORE CLIMBING ON THE PLATFORM BE SURE IT IS STRONG AND SECURE. CHECK FOR ROT OR DETERIORATION. REPLACE IF REQUIRED.

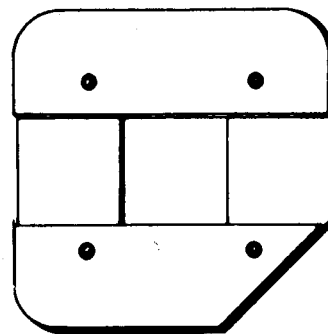

PLATFORM

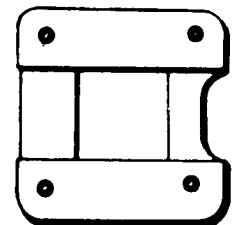

OILING PLATFORM  
(For Widespread Towers  
only with 12-ft., 14-ft.,  
16-ft. Mills)

PLATFORM BOLT



FIGURE 1

# SAIL SECTION ASSEMBLY INSTRUCTIONS

Assemble the sails into six sail section assemblies. Follow below instructions carefully:

- Step 1.** Slide sail rib (#101) over small end of sail toward the large end until the rib fits the rectangular notch in the sail, as indicated in sketch. Repeat this for all 18 sails.
- Step 2.** Lay three (3) sails (#100) in position as shown in sketch.
- Step 3.** Connect inner band (#35) to sails with bolts and locknuts.  
Do not tighten locknuts at this point.  
Caution: Be sure inner band is installed in correct position, as indicated in dimension 2 of sketch.
- Step 4.** Slide the outer band (#34) through rectangular notches in sails until bolt holes of outer band match bolt holes in sail ribs (#101). Secure sail ribs to outer band with bolts and locknuts.  
Caution: Be sure outer band is installed in correct direction, as indicated in dimension 1 of sketch.
- Step 5.** Tighten all locknuts in wheel section.
- Step 6.** Repeat above procedure for other five (5) sections.
- Step 7.** After six (6) sections have been individually assembled, follow instructions which follow for assembling wheel.

## CHECKLIST FOR NO. 799 WHEEL COMPLETE

	6-foot	8-foot	10-foot	12-foot	14-foot	16-foot
Sails	18 X-100	18 A-100	18 B-100	18 D-100	18 E-100	18 F-100
Sail Ribs	18 X-101	18 A-101	18 B-101	18 D-101	18 E-101	18 F-101
Outer Bands	6 X-34	6 A-34	6 B-34	6 D-34	6 E-34	6 F-34
Inner Bands	6 X-35	6 A-35	6 B-35	6 D-35	6 E-35	6 F-35
Wheel Arms w/nu: washer	12 X-736	12 A-736	12 B-736	12 D-736	12 E-736	12 F-736
Bolts for Sails	56 1/4" x 5/8"	56 1/4" x 5/8"	19 1/4" x 3/4" 38 5/16" x 3/4"	56 5/16" x 7/8"	56 3/8" x 1"	56 1/2" x 1 1/4"
Locknuts for Sails	56 1/4"	56 1/4"	19 1/4" 38 5/16"	56 5/16"	56 3/8"	56 1/2"
Furl Wire	25 A-582	25' A-582	25' A-582	25'	25'	25'

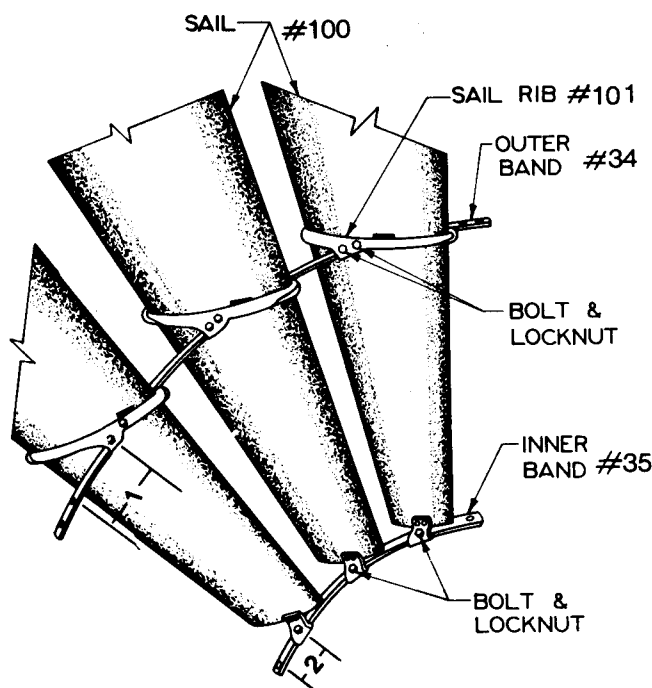

SAIL & SAIL STRUCTURAL SUPPORT  
(FIGURE 2)

MILLS	6'	8'	10'	12'	14'	16'
Dimension 1	7/8"	1 3/8"	2 3/8"	1 7/8"	3 3/8"	3"
Dimension 2	1 7/8"	2 5/8"	3 1/2"	3 3/4"	4 3/8"	5 1/8"

## Check Your Material

1. REMOVE THE CRATED MOTOR FROM THE CRATE AND INSPECT FOR CONCEALED DAMAGE.
2. OPEN THE BOLT BOX AND CHECK CONTENTS WITH CHECKLIST.
3. CHECK OTHER COMPONENT BUNDLES FOR DAMAGE.

## Assembling The Mill

Assemble the vane to the tailbone using the bolt and U-clamps provided. See Figure 3.

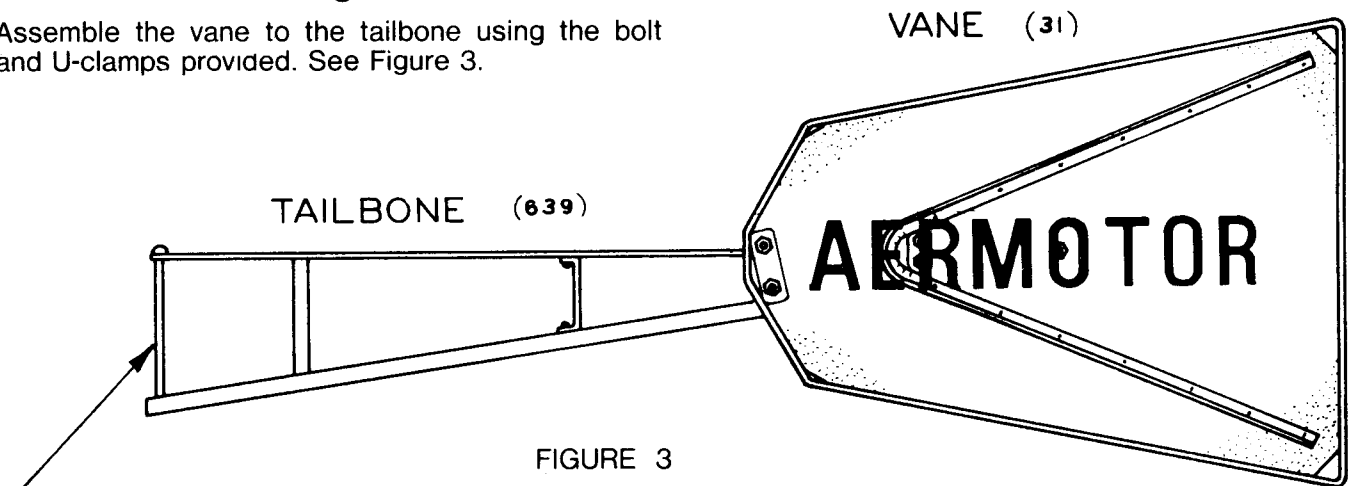
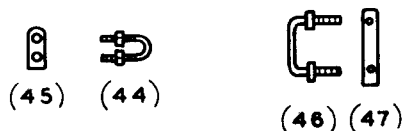

FIGURE 3

PIVOT BOLT FOR TAILBONE (510)



## ASSEMBLE MAST PIPE WITH BASE INTO TOP OF TOWER

1. Put the mast pipe into the top of the tower (see Figure 1, Page 3) and put a short bolt in the base on the corner post to which the furl handle at the foot of the tower is to be attached. With the two long bolts attach the supporting angles of the furl lever to the side opposite the one on which the furl handle is to be so the furl wire will pull across the tower and clear the inner edge of the platform. (Figure 4)
2. Remove the locknut #578 and lockwasher #579 from the top of the mast pipe (Figure 4). GREASE PACK THE FRICTION WASHERS #576 IN THE TURNTABLE BASE AND ALSO THE MAST PIPE STEM.
3. SLIDE THE UPPER FURL RING DOWN OVER THE MAST PIPE AND POSITION IT ON TOP OF THE LOWER FURL RING.

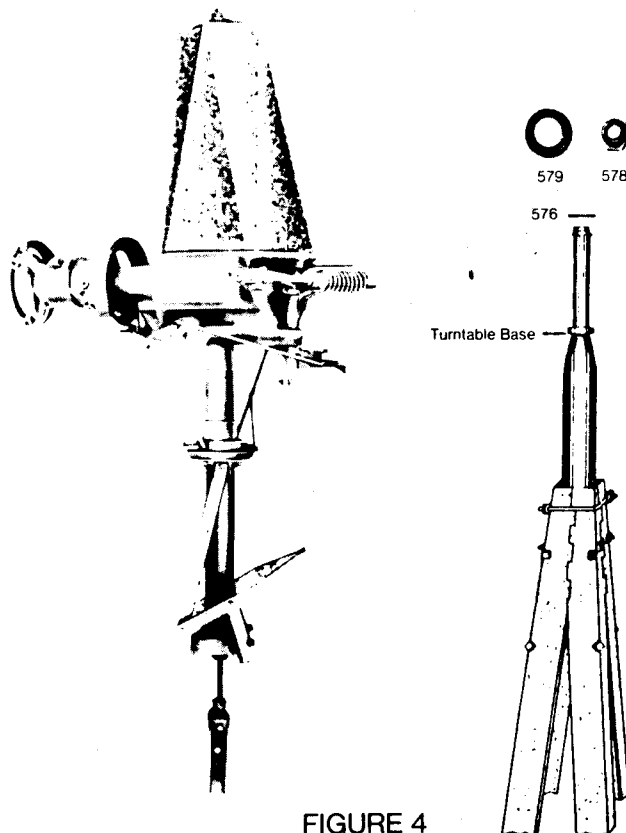

FIGURE 4



4. Install the crated motor on the mast pipe by use of gin pole, block and tackle or crane, depending on the size of mill.
5. Put the lockwasher and locknut in place on top of mast pipe and tighten the nut.
6. Remove the round pivot bolt #510 from the tailbone (Figure 3) and put it through the lugs on back of the main casting #802 of the crated motor and through the buffer spring brackets #654 and 655.
7. Hook the head of one of the furl arms into brake lever casting #786 and put it on the pivot pin on the underside of the arm which carries the wheel. Put on the washer and install cotter pin and open up the cotter.
8. Hook the head of the other furl arm (#528) into tailbone casting #585 and then put #585 on the lower end of the #510 pivot bolt on which the tailbone pivots. Push the casting clear up to the lower lug of the main frame casting and when in this position hook the end of the connecting rod #527 into the hole for it in the #786 brake lever. The three rods which operate the furling device should all be straight. If any of them have been bent in shipping or handling they should be straightened before they are assembled in place. All of these parts can be put on without bending, if properly done.
9. Install the tailbone and vane assembly, attaching it to the #510 pivot bolt. Be sure the lug of tailbone casting hooks over the tailbone bar so that it will furl the tailbone when mill is furled out of gear. Use of a gin pole, boom or crane will make installation of vane and tailbone easier. Bolt the shank of the buffer device #659 into the crosspiece of the tailbone. Work the furling lever up and down several times to make sure all parts move freely.

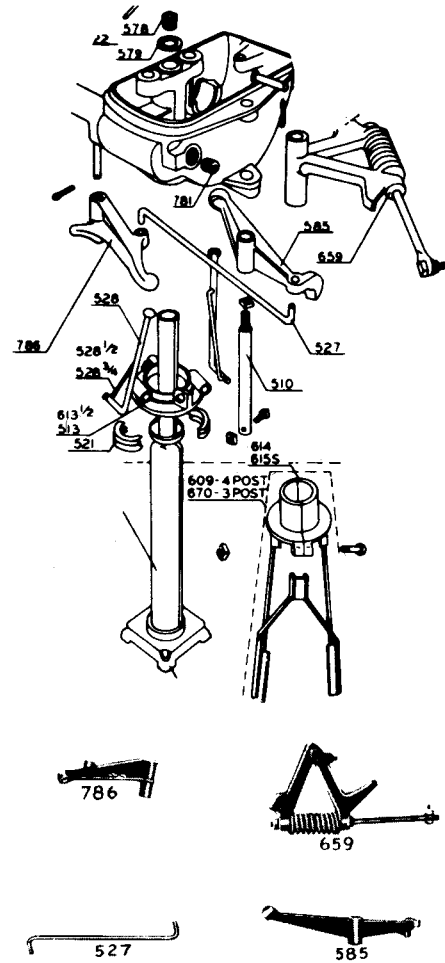

FIGURE 5

10. Install the #171 pump rod up through base of mast pipe, remove cotter and pin #610 in #608 yoke and position top end of #171 pump rod into bottom of yoke, insert pin thru yoke and pump rod, insert cotter key and spread (Figure 6).
11. Screw the spring holder #580 into the hole between the pivot and the buffer lug. WHEN TIGHT IT SHOULD STAND WITH THE OPEN SIDE AWAY FROM THE TAILBONE.
12. Hook the vane spring into one of the holes in the tailbone and the other end into the spring holder #580. THE END OF THE SPRING WITH THE LONG HOOK GOES IN THE TAILBONE WITH THE OPEN END OF HOOK UP. To obtain maximum speed of the wheel, hook the spring in the hole farthest out on the tailbone. When it is desired to have the mill regulate off at low speed, connect the spring in the first hole. This puts less tension on the spring and will furl out sooner. For intermediate speeds select the hole

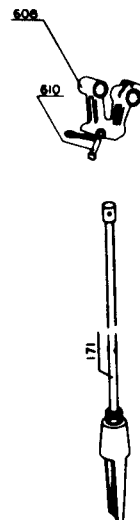

FIGURE 6

which you find by experience will give the right speed you desire.

B-736	7/16"	- 14	N.C.	Thread
D-736	1/2"	- 13	N.C.	Thread
E-736	5/8"	- 11	N.C.	Thread
F-736	3/4"	- 10	N.C.	Thread

13. Attach the furl wire to the end of the furl lever and bring it down through the platform and across the tower to the furl handle on the opposite corner of the tower. When put on 4 post towers in this way the wire will clear both the platform and pump pole. On 3 post towers put a loop of wire around the furl wire and corner post between the platform and the platform bolt to hold the furl wire away from the pump pole. Adjust the furl handle so that the arms of the furl lever will bear on the nuts of the bolts which hold the supporting angles when pulled all the way down.

14. Furl the mill out of the wind and be sure the furl handle is secure so there will be no danger of the mill turning into the wind while the wheel is being assembled.

15. Install the 12 wheel arms #736 into hub of crated motor. The end with the square head screws into the hub. Use a wrench with smooth jaws on the squared head and turn each arm clear up to the shoulder. (Do not use a pipe wrench as it can ruin the galvanizing.) Stop the first arm of each pair one-quarter turn back so that the arm crosses will not interfere when the second arm is being screwed in. Then turn the first arm to its place and line up the arm crosses so that they are parallel with each other and so that the offset ends will be lined up to receive the inner wheel band. The outer ends of the arms will all stand straight out, and in line; and will go through the holes in the outer bands without bending. Do not try to spring the arms out of their normal position when putting on the wheel sections. The arms cross each other at the inner band and the arm crosses stand at right angles to the bands. If the inner bands do not fit into the depressed ends of the arm crosses, you have not turned the arms to the right position, or you have misplaced the outer ends of the arms. It is very important to get them right so the wheel will run true. Do not undertake to bend these arms, or the threaded portion at the end. Bear in mind that when we say, "The end holes of the outer band of the same section," that is just what we mean.

16. If it is necessary to clean up the threads in the wheel hub, the thread size of the #736 wheel arm are as follows:

X-736	11/32"	V-Thread	18 per 1"
A-736	13/32"	V-Thread	16 per 1"
B-736	15/32"	V-Thread	12 per 1"
D-736	19/32"	V-Thread	13 per 1"
E-736	23/32"	V-Thread	11 per 1"
F-736	25/32"	V-Thread	10 per 1"

The outer end of the wheel arm where outer band of wheel attaches are following:

X-736	5/16"	- 18	N.C.	Thread
A-736	3/8"	- 16	N.C.	Thread

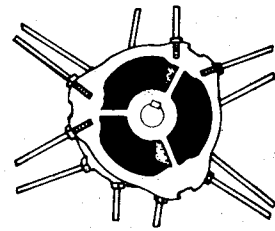

HUB - CROSS SECTION

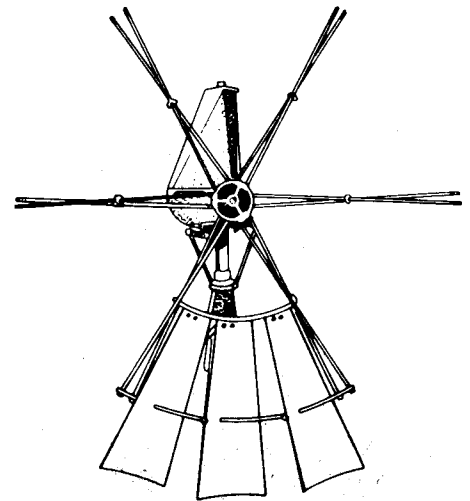

SAILS OF AERMOTOR WHEEL

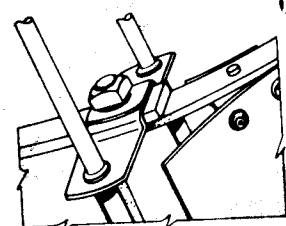

WHEEL ARMS & ARM CROSSES

ASSEMBLING THE WHEEL SECTIONS - FIGURE 7.

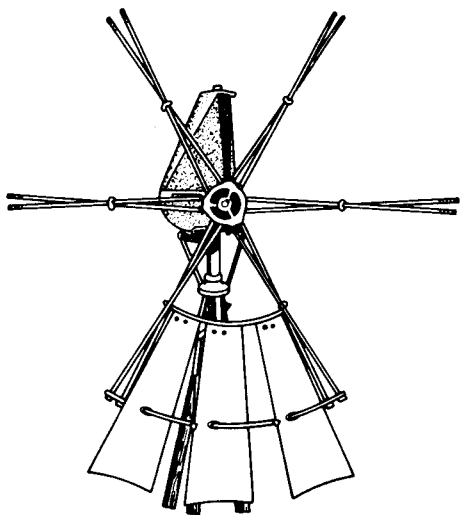

FIGURE 8

Illustration on assembling the wheel on a stub tower or standing tower. Turn the hub until one pair of the front arms (on hub) points downward and put in the first section of sails with the concave side toward the front. NOTE: BE SURE THAT THE ENDS OF THE FRONT ARMS GO TO THE OUTER HOLES OF THIS SECTION.

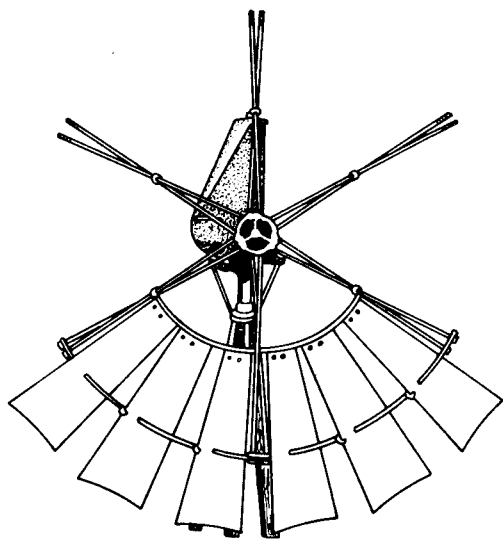

FIGURE 9

Turn the wheel to the left and put on another section. THE REAR ARMS (ON HUB) SHOULD GO TO THE OUTER HOLES OF THE SECOND SECTION.

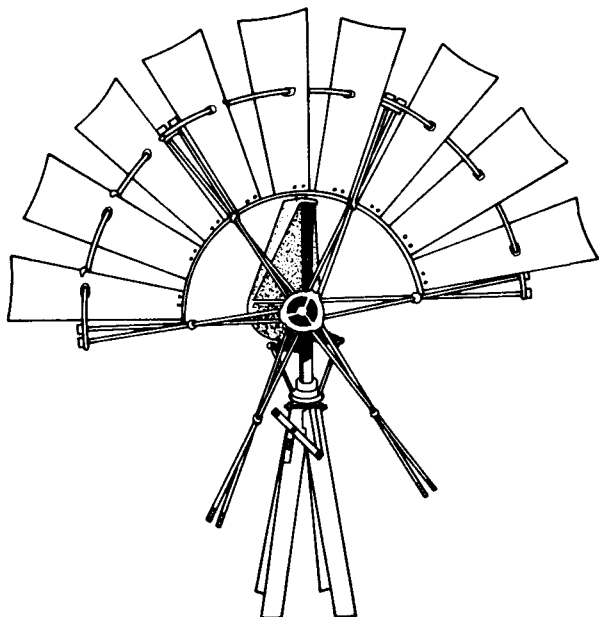

FIGURE 10

When the third section is on, turn that half of the wheel up so it will balance easily. Turn the nuts on the ends of the arms only two or three threads when putting on the sections. If you screw the nuts up before the wheel is all together you will throw the wheel out of true and you will be unable to get in the last section.

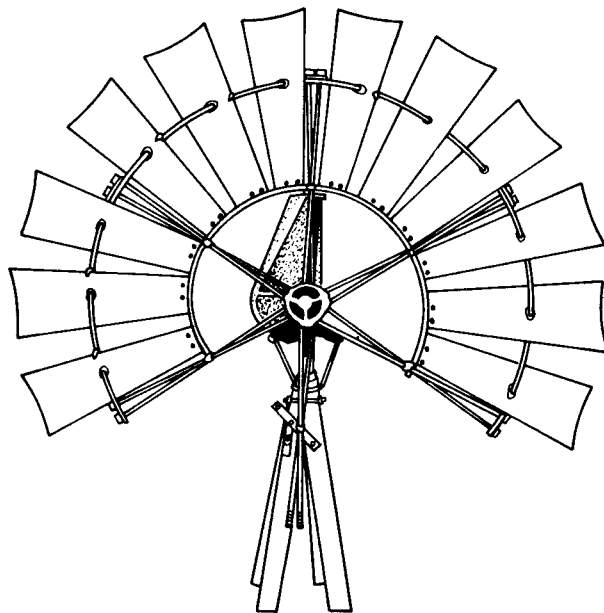

FIGURE 11

Install the fourth and fifth section.

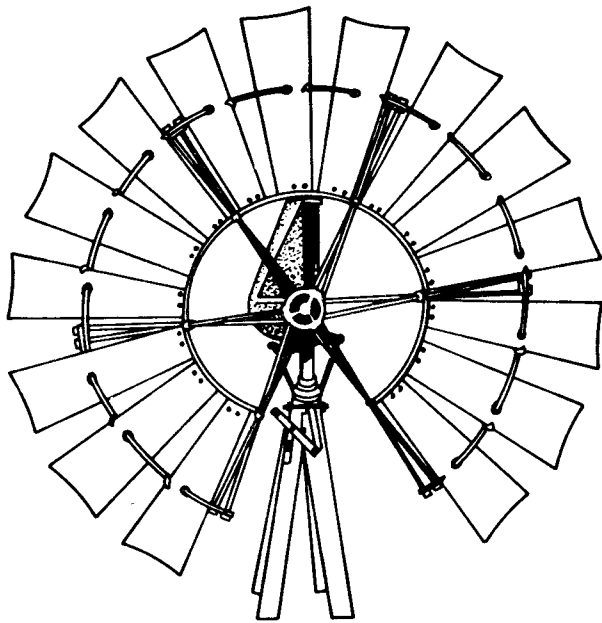

FIGURE 12

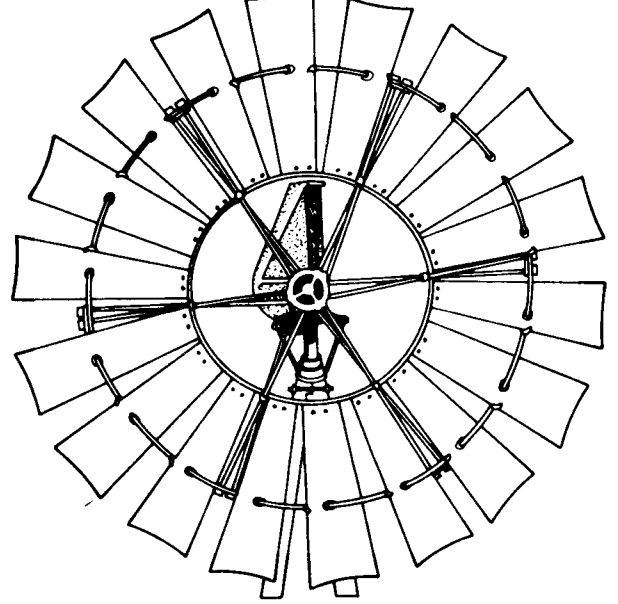

FIGURE 13

When the sixth section is installed, the outer wheel band must be on the inside, so the lap joints on the outer band are the same at all six locations. This is accomplished by temporarily removing the end of the outer band on the first section assembled, and inserting the end of the outer band of the last section assembled on the wheel arms first. Also see Figure 14. (A and B must be reversed.)

When the sections are all in, bolt the arm crosses to the inner bands by putting a bolt through the ends of both bands and then through both parts of the arm cross. The bolt should go through the wheel bands first. A punch and vise-grip pliers will be helpful in aligning and temporarily holding in position while bolt is inserted. See insert (Figure 7).

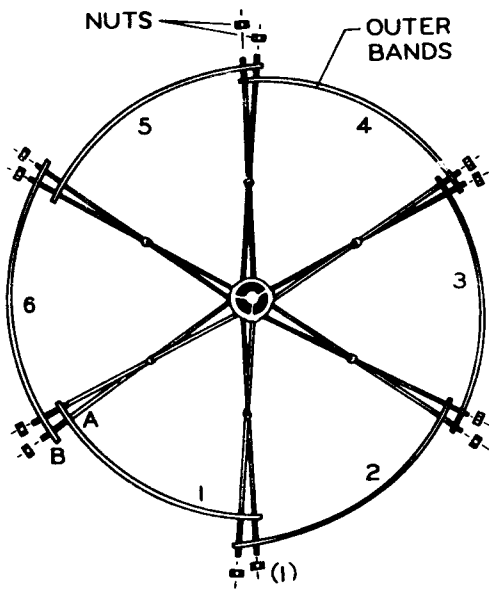

FIGURE 14

Final lap assembly, A & B must be reversed.

**IMPORTANT:**  
 AFTER ALL SIX WHEEL SECTIONS HAVE BEEN ASSEMBLED TO WHEEL ARMS AND ALL INNER BANDS ARE BOLTED TOGETHER, START TIGHTENING GRADUALLY. TIGHTEN UP A COUPLE TURNS AND REVOLVE WHEEL AND TIGHTEN UP THE NEXT SET. KEEP REVOLVING WHEEL AND GRADUALLY TIGHTEN UNTIL ALL ARE TIGHT. THE AERMOTOR WHEEL IS A TENSION TYPE WHEEL AND WHEN PROPERLY ASSEMBLED FORMS A STRONG AND VERY RIGID WHEEL OF HIGH EFFICIENCY AND STRENGTH.

## FILL GEAR CASE WITH OIL

1. Remove helmet and put in required amount of oil in the gear case.
2. Quantities are shown below for the various sizes of mills.

X —	6 Foot	1 Quart
A —	8 Foot	2 Quarts
B —	10 Foot	2 Quarts
D —	12 Foot	4 Quarts
E —	14 Foot	8 Quarts
F —	16 Foot	8 Quarts

Under normal conditions this supply will be enough to keep the mill oiled for a year.

3. We recommend the use of Aermotor Oil because it is thin enough to flow freely through all oil passages, and remains fluid in cold weather.
4. We recommend the use of a non-detergent, lighter than #10 weight.
5. Put on the helmet #560 and be sure that it fits well down over the gear case. Use care in putting on the helmet and see that the inner flange does not get caught on the rim of the gear case. It should fit down on the inside of the casting to keep the oil from splashing out. Use the nut on top of the helmet to hold it in position and to keep out the rain.

## Pump Pole

1. Connect the pump rod #171 to the pump pole.
2. We recommend the pump pole be wood so that in case something catches or is hung up, the wood will break and thereby prevent damage to the gear case.
3. Turn the wheel until the pump pole is at the lowest point of the stroke and attach the pump pole connection so the plunger in the well cylinder cannot strike the lower check valve of the cylinder.
4. Turn the wheel around by hand a few times to make sure the pump will give a clear stroke as long as that of the mill. If the cylinder or pump is not suitable for use with this windmill, the cylinder or pump should be replaced.
5. Our table of pumping capacities will show you what size of cylinder to use with each size of Aermotor mill for any elevation.

SEE THAT THE TURNTABLE, FURL SWIVEL, PUMP ROD #171 ARE LUBRICATED WHEN NECESSARY.

MAKE DOUBLY CERTAIN THAT ALL NUTS ON BOTH THE MILL AND THE TOWER ARE DRAWN UP TIGHT.

## GENERAL INFORMATION ON ERECTING WINDMILLS

1. The Aermotor windmill and tower must stand plumb. If it does not, it will not regulate well and cannot face the wind properly.
2. The pump must stand in line with the pump pole. If it doesn't, it will run hard, will fail to work in a light wind, wear rapidly, break and cause trouble.
3. The plunger in the cylinder must not strike the top or bottom of the cylinder. If it does, it will cause endless wear, breakage and trouble.
4. If your pump has a handle, do not leave the handle connected and start the mill. Few pumps have a hand stroke as long as the windmill stroke and the two should never be connected at the same time.
5. Your windmill should be at least 15 feet above the highest surrounding objects, such as buildings and trees; with a radius of 400 feet, or you will not get good wind exposure, nor will it run in a light wind. Irregular gusts around obstructions will endanger your mill and tower.
6. The cylinder should not be larger nor the pipe smaller than the size designated for your depth of well in our table of capacities. (If the cylinder is larger and the pipe smaller your wheel will not run in a light wind.)
7. In a steel tower the corner posts, girts and braces must be straight and all girts and braces must be in place. The anchor posts must stand in line with the corner posts. (They are absolutely essential to the strength of the tower.)
8. An Aermotor windmill can be erected on an existing tower, by use of a stub tower, but it is the responsibility of the erector to determine if the existing tower is safe and strong enough to support the size of the windmill being installed.

## OLDER MODEL MILLS

1. Open-gearred models were discontinued in 1915.
2. Model 602 mills were manufactured from 1916 until 1933. These had the V-shaped wheel arms with the bearings for hub shaft and large gears poured into main frame. Parts for crated motor #602 are not available. Necessary to order:
  - 1 Crated Motor Model 802
  - 12 #736 Wheel Arms
  - 1 #28 Vane Spring
  - 1 #171 Pump RodWheel, vane, tailbone, mast pipe interchangeable for 602 models.

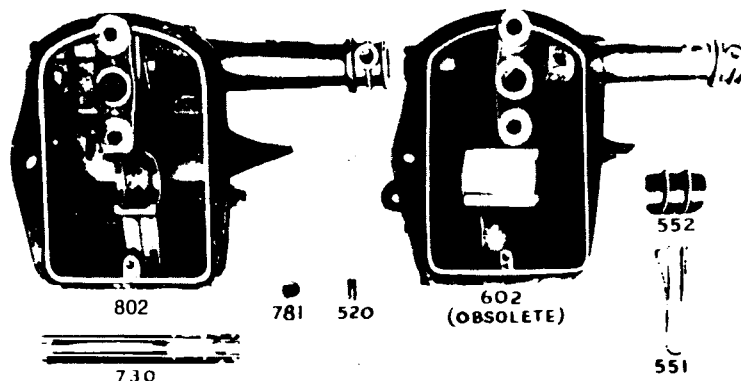

# Instructions for Changing the Stroke

1. The mill was assembled on the long stroke at the factory.
2. Capacity tables are based on the long stroke of the mill.
3. Setting the mill on the short stroke decreases the capacity by 25%.
4. Setting on the short stroke may accommodate the present cylinder in the well if the barrel length is not sufficient to allow clearance of the long stroke.
5. On the short stroke the mill will run in a lighter wind.

## To Change This Mill to the Short Stroke

1. Turn the large gears until the pitmen are near the bottom of the stroke. (If the pump rod is under load, support the pump rod yoke with a wood block as shown in Figure 16. A piece the size of the pump pole will do.)
2. Remove cotter pin at one end of No. 522 shaft and push the shaft out from the pitmen, yoke and guide wheel.
3. Turn large gears until lower ends of pitmen are above rim of gear case. Remove cotter pins and No. 622 bolts, and take both pitmen off the gears.
4. Turn the large gears about one-half revolution, or until short stroke bosses are above rim of gear case, so that pitmen can be placed on them. These bosses on the large gears are the ones that are closest to the center of the gears.
5. Place both pitmen on the short stroke bosses, making sure to replace the No. 622 Bolts and the cotter pins that hold the lower ends of the pitmen on the large gears.
6. Turn gears until pitmen are near bottom of stroke, as in Figure 17.
7. Replace No. 522 shaft thru **lower holes in upper ends of both pitmen**, thru pump rod yoke and guide wheel. Be sure to replace cotter pin in No. 522 shaft.
8. After changing the stroke, be sure that the oil ring rolls on the large gear at the bottom of the stroke. Turn the wheel to be sure everything works freely before putting the mill in operation.

### IMPORTANT:

WHEN CHANGING STROKE, BOTH ENDS OF PITMEN ARMS MUST BE CHANGED AS SHOWN.

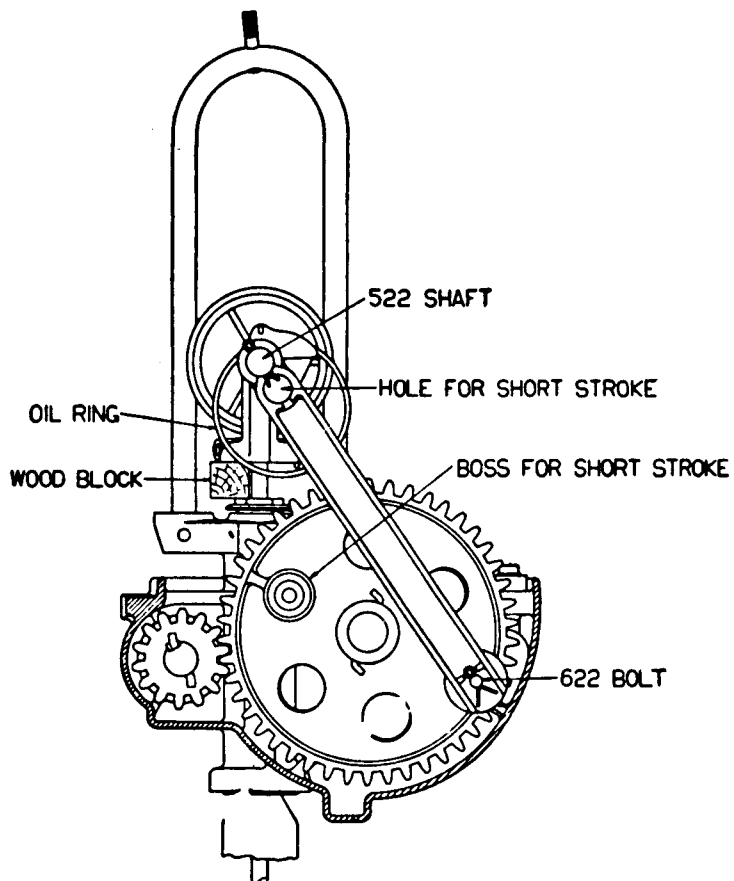

FIGURE 16  
MILL SET ON LONG STROKE

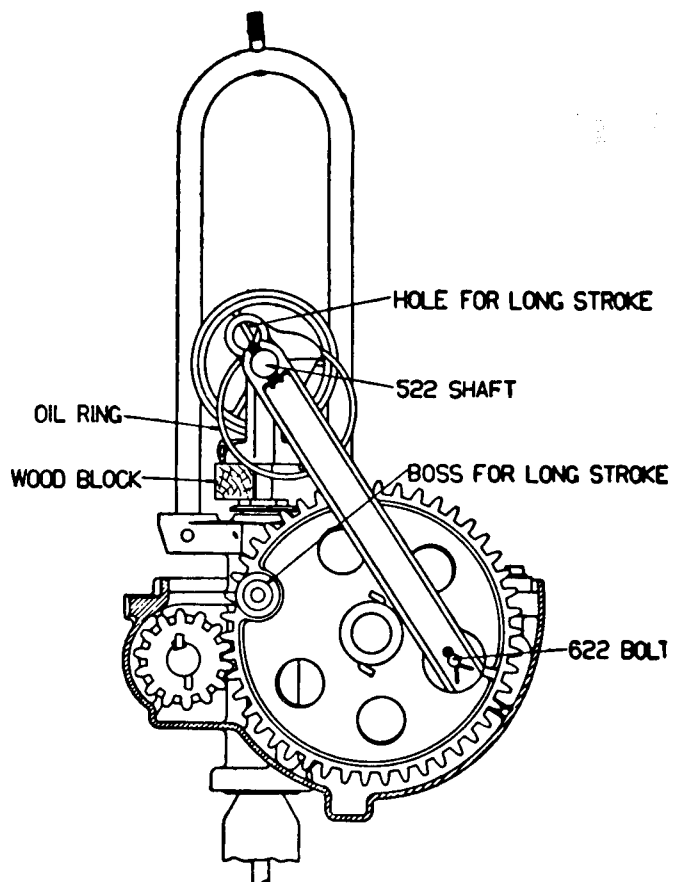

FIGURE 17  
MILL SET ON SHORT STROKE



## REPLACEMENT OF HUB AND SHAFT #703

The hub and shaft are supplied as one unit, and not sold separately as the shaft is welded into the hub to assure a tight fit.

1. Wheel sections and wheel arms must be removed. Depending on the size of the mill and the equipment available, it may be advisable to remove mill and lower to the ground.
2. Remove the pipe plug in the hub.
3. With the hole for the pipe plug straight up, insert screwdriver and remove #520 oil collector. **NOTE: OIL COLLECTOR MUST BE REMOVED BEFORE YOU CAN PULL HUB AND SHAFT OUT.**
4. Remove the pipe plug from the back side of the gear case. Remove #522 shaft and large gear assembly with pitmen from gear case which will make it easier to get at the small gears on shaft.
5. Remove the pin which holds the back pinion gear on the shaft and also retains the #744 long key.
6. Be sure the keyway on the shaft is straight down so that it doesn't break the #718 spout washer when shaft is pushed out. (The #718 spout washer has an opening on bottom side to allow #744 key to pass through.)

7. After hub and shaft have been removed, remove the following and examine for wear and replace if necessary:

- #730 Removable bearing
- #517 Spring for spout washer
- #718 Spout washer
- #708 Removable bearing between pinion gears
- #704 Pinion gears
- #744 Long rectangular key which positions and holds #704 gears
- #520 Oil collector

**NOTE:** Always use a new #520 oil collector as this has to rub the inside of the oil pocket of the hub, to pick up the oil and return it to gear case.

8. Reassembly of hub and shaft.

- a. Insert #708 pinion bearing in main casting.
- b. Insert #730 sleeve bearing in location.

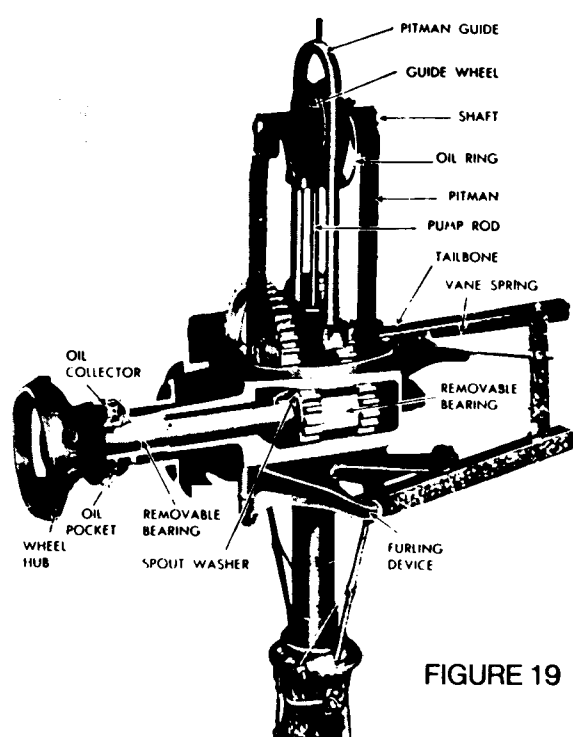

FIGURE 19

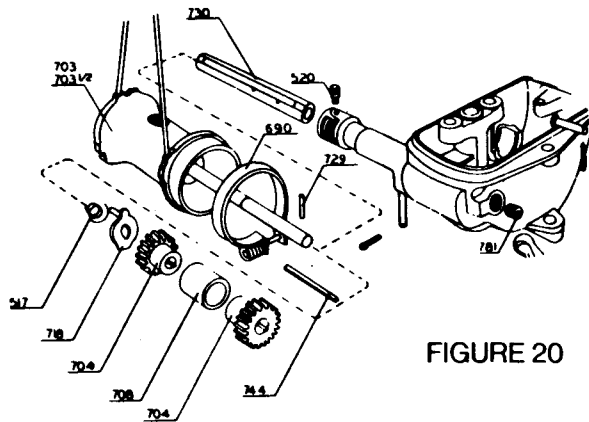
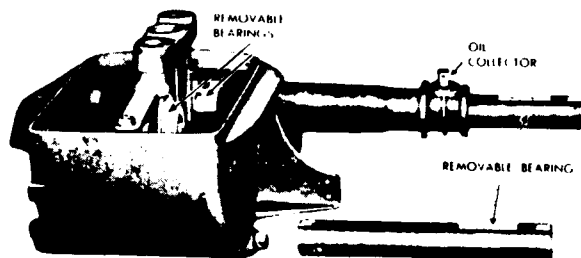
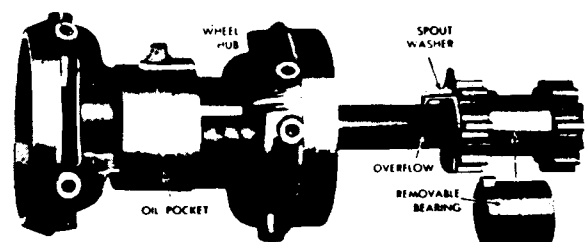

FIGURE 20



Main Frame

FIGURE 21



Wheel Hub With Key

FIGURE 22

- c. Oil the shaft and #730 and insert shaft part way, and then the #704 pinion gears.
- d. Insert #517 spring and #718 spout washer in correct position.
- e. Push hub and shaft into final position.
- f. Align pinion keyways with shaft keyway and insert #744 key in from hole in backside of case.
- g. Install cotter pin through shaft and bend over.
- h. Install new oil collector #520. Tighten with screwdriver.
- i. **IMPORTANT:** Seat oil collector by slowly turning wheel. COLLECTOR MUST RUB THE INSIDE OF THE HUB IN ORDER TO PICK UP THE OIL AND RETURN IT TO THE GEAR CASE.
- j. Install plugs in hub and back of main gear case.

### REPLACEMENT OF #752 BEARING BETWEEN LARGE GEARS #705. See Figure 23.

1. Remove large gear assembly from gear case.
2. Remove pitmen arms.

FIGURE 23

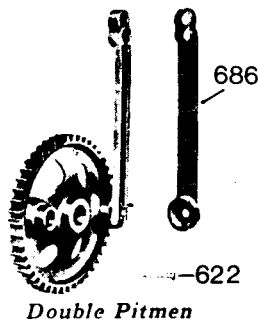
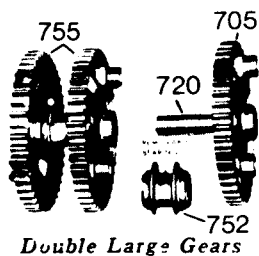

### PROBLEM AND CAUSE

1. **MILL FURLS OUT, BUT WHEEL CONTINUES TO TURN SLOWLY**
  - a. Excess wear in upper furl lever connections.
  - b. Brake band #690
  - c. Furl lever linkage worn in rivets and connections of #609.
2. **MILL JERKS WHILE OPERATING**
  - a. Cylinder leathers may have swelled and binding in cylinder barrel.
  - b. Cylinder barrel may have been crushed due to pipe wrench being used on barrel.
  - c. Pump rod coupling may be catching at pipe joint.

3. Remove #721 pin from #720 shaft.
4. Remove one of the #705 gears and slide bearing off.
5. Examine #720 shaft and replace if worn.
6. On reassembly **be sure** the teeth and pitmen bosses are lined up on both large gears. If not the pitmen arms will work in a bind and cause undue wear or breakage.

### REPLACEMENT OF #523 GUIDE WHEEL (For Pitman and Yoke) See Figure 24

1. Remove large gear assembly.
2. Mark #508 pitman guide so that it is not reversed when reinstalling. If reversed the #588 stud is in wrong location and #560 helmet will not position correctly.
3. Remove the two pins at bottom of #508 which secures pitman guide into case.
4. Replace #523 guide wheel in same direction as old one was.
5. Be sure #507 oil ring is not bent or damaged.

FIGURE 24

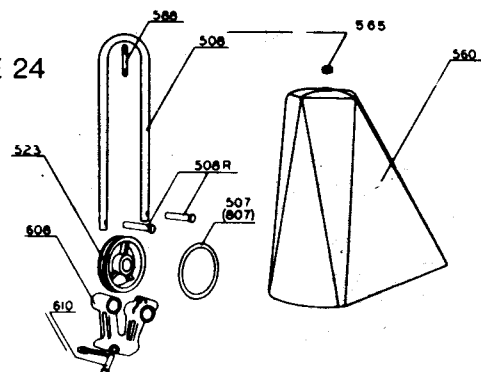

### REMEDY

- a. Furl arms #528 need to be replaced with 528½ or 528¾ which are extra long to compensate for wear. A lot of #690 brakes are installed but do not correct problem, as not enough pressure is being applied due to wear in linkage.
  - b. No brake lining is used on band, depends on metal contact. Replace if worn excessively.
  - c. Replace furl lever #609 on 4 post tower or #670 if mill is on 3 post tower.
- a. Replace leathers.
  - b. Never use pipe wrench on cylinder barrel, especially a brass barrel. Replace cylinder if crushed or scored.
  - c. Find problem connection and correct.

## PROBLEM AND CAUSE

## REMEDY

d. Stuffing box nut may be too tight and binding.

### 3. MILL KNOCKS AT BOTTOM OF STROKE

a. Yoke #608 is hitting top of mastpipe locknut #578.

b. Turntable washers worn and let crated motor drop.

c. Plunger in cylinder hitting cage of lower check valve in cylinder.

d. Stuffing box may be too tight.

e. Pitmen arms may be worn excessively.

### 4. PITMEN ARMS KEEP BREAKING

a. Large gears misaligned. Causes pitmen arms to operate in a bind.

b. Bearing #752 between large gears worn excessively.

c. Replaced only one pitmen or one gear in field.

d. Mill may be overloaded.

e. Mill may be loaded too much on down-stroke due to stuffing box or counter-balance. Pump pole in tower will usually bend or buckle a little.

### 5. OIL LEAKING DOWN MAST PIPE

a. Too much oil in gear case, and runs into hole for oiling turntable.

b. Lockwasher #579 for top of mastpipe may be off to one side and rubbing on inside of large gears and picking up oil.

### 6. OIL LEAKING AROUND HUB AND ONTO WHEEL

a. Oil collector #520 plugged and does not pick up oil from oil pocket inside of hub.

b. Using too heavy a grade of oil which won't flow and plugs passages.

c. #730 shaft bearing may be worn excessively.

d. May be using detergent type of oil.

d. Loosen and repack stuffing box. If rod in stuffing box is pitted or scored, replace rod.

a. Motor position has to be raised.

b. Install with #521 split washers as required on mast-pipe at turntable and greasepack.

c. Rod adjustment necessary. Shorten pump rod. (Rod will sometimes stretch a little after installation, especially on deep setting.)

d. Loosen and repack gland.

e. Replace.

a. Remove gears #705 and line up boss on each gear so each is in alignment with each other.

b. Replace #752 bearing and #720 shaft if necessary.

c. Always replace both pitmen arms or both gears, so load is distributed evenly.

d. Check recommended table and cylinder size. Setting mill on short stroke may alleviate condition.

e. Check stuffing box or correct counter-balance.

a. Do not overfill. Check helmet #560 for bullet hole where water could get into gear case and float oil out.

b. Be sure lockwasher #579 is centered and locknut is tight.

a. Remove #520 oil collector and clean and flush out oil passage with kerosene.

b. Drain and flush system with kerosene. Refill with correct weight oil.

c. Replace if necessary.

d. Use a non-detergent type of oil.

# AERMOTOR WINDMILL MAINTENANCE and INSPECTION

## 1. TOWER

- a. Check to be sure tower is plumb and true.
- b. Check girts, angle braces. Are they bent or missing?
- c. Check all bolts to be sure they are tight.
- d. Check condition of wood pump pole guides, splices.

## 2. WHEEL CONDITION

- a. Are all bolts tight or missing in inner and outer bands?
- b. Check rivets or bolts in sail ribs
- c. Check hub and wheel arms.
- d. Does wheel turn true and free?

## 3. WINDMILL HELMET IN POSITION

- a. Check for damage, such as bullet holes.
- b. Is helmet positioned correctly?

## 4. FURLING DEVICE

- a. Check linkage connections for wear or missing rivets.
- b. Check vane spring for wear at connections.

## 5. CHECK TAILBONE, VANE

- a. Is tailbone bent or pivot bolt nut on securely?
- b. Check vane spring for wear at connections.

## 6. SECURE WHEEL SO IT CANNOT TURN NOR CAN MILL SWING AROUND

- a. Check wood platform for rot, oil which would make it slick.
- b. Check area for bees, wasps, or other insects and eliminate before working on tower, for your own personal safety.

## 7. REMOVE NUT SECURING HELMET AND REMOVE HELMET

- a. Check oil level - is oil clean?
- b. Examine large gears for wear, broken teeth.
- c. Check pitman arms #686 for wear.
  - (1) Is #622 pin and cotter in position?
  - (2) Check for side play of pitman arms.
  - (3) Check upper shaft for guide wheel and yoke.
- d. Is #751 bearing bar securing gears properly?
- e. Try moving large gears sideways for wear in #752 bearing.
- f. Check oil ring
  - (1) Is it round or egg shaped - must be round to roll on large gears at bottom of stroke.
  - (2) Should hit 3 to 4 teeth and roll.
  - (3) Provides lubrication to upper guide wheel and shaft.
- g. Is spring #517 holding #718 spout washer in position?
  - (1) Spout washer must rub small pinion gear.

## 8. CHANGING OIL AND LUBRICATION

- a. Remove the drain plug on the bottom of case.
  - (1) Catch oil in container so that it cannot get into well or onto platform where it could become slick and dangerous.
- b. Look for grit, sand in bottom of gear case.
- c. Turn wheel so pipe plug in wheel hub is on top.
  - (1) Remove pipe plug in hub and flush out the oil collector and passages with kerosene.
  - (2) It may be necessary to remove the #520 oil collector to flush return passage with kerosene.
  - (3) Replace #520 oil collector and tighten. Oil collector must rub the inside of the hub. to pick up oil and return this oil to gear case.
  - (4) If installing new #520 oil collector:
    - a. Screw in securely.

# AERMOTOR WINDMILL MAINTENANCE and INSPECTION

- b. Turn wheel slowly by hand. This will seat the oil collector and it should drag or rub against hub.
- c. Check again to see that oil collector is tight.
- (5) Replace pipe plug in hub housing.
- d. Replace drain plug in case and tighten securely.
- e. Refill the gear case with oil.
  - (1) Do not overfill with oil, as too much oil may cause overflow at the wheel-hub.
  - (2) DO NOT USE HEAVY OIL. Use a light oil that flows freely to all working parts. Heavy oil may clog the oil passages, causing extra wear on some of the working parts, due to lack of lubrication.
  - (3) AERMOTOR OIL. Non-detergent oil. (Detergent oil will adhere to shaft and get by the oil collector. Not like a car engine where excessive heat tends to break down the oil, and no carbon build-up, so non-detergent oil is recommended.)
- f. Oil the turntable.
  - (1) Through the hole in the main frame near the top of the supporting pipe.
- g. Oil the furl ring.
  - (1) Some remove the plug and insert a zerk fitting so they can grease it.
- h. Grease pack the pump pole swivel.

NOTE: In some sections of the country, especially where there are a lot of dust storms, it may be advisable not to oil or grease external parts, such as furl ring, tailbone pivot bolt, brake lever pivot, etc., as sand dirt becomes inbedded in grease or oil and causes further or faster wear.

## 9. CHECK #608 YOKE AT BOTTOM OF STROKE

- a. Turn mill over slowly and at bottom of stroke be sure bottom side of #608 yoke is not striking mast pipe locknut.
  - (1) If it hits bottom of stroke or is close to striking
  - (2) Needs turntable washer #521 (split washer) to raise motor position.
    - a. Necessary to lift up the motor and block it up.
    - b. Grease pack the #521 split washer before installing.
    - c. Be sure to tighten locknut #578 when completed.

## 10. INSTALL HELMET #560

- a. Very important to position correctly, to keep out dust, dirt and rain.

## 11. CHECK FOR LEAKS AT DRAIN PLUG

## 12. FIELD SERVICE AND REPAIR

- a. On site or location.
  - (2) Most common parts requiring replacement:
    - a. Pump rod #171 and #610 pin for yoke.
    - b. Pitman arms #686. Always replace both pitmen - balanced load.
    - c. Large gears #755. May just require #752 bearing for large gears.
    - d. Vane spring #28.
    - e. Shaft #522 for guide wheel and yoke.
    - f. Oil collector #520.
- b. In shop.
  - (1) Depends on equipment for removing mill from tower.
  - (2) Shop facilities.
  - (3) MAJOR REPAIR OR REPLACEMENT.
    - a. Hub and shaft #703.
    - b. Sleeve bearing #730 or 830 for hub and shaft.
    - c. Pinion gear bearing between small pinion gears - bearing #808 or 708.
    - d. Small pinion gears #704.

## **PUMPING WITH A WINDMILL**

We are concerned that all Aermotors should be well erected so that they may be able to render the best service. To insure this, it is necessary that the mill have a good wind exposure, and the load must be a moderate one. The windmill should have a clear wind exposure of fifteen feet above obstructions within 400 feet, and the size of cylinder and pipe should correspond closely to our recommendations. In no case should 1-inch pipe be used for the well pipe no matter how small the cylinder.

We cannot condemn too strongly the practice which has been established in some localities of using 1-inch pipe in deep wells. This is done under the impression that by reducing the volume of water in the pipe the load upon the windmill is reduced. This is not true. The weight of the water to be lifted by the mill is determined by the diameter of the cylinder and the length of stroke.

Leaving out friction, there would be no difference in power required to raise a given volume of water through pipes of various sizes. If the cylinder has the capacity to furnish 500 gallons of water per hour, that weight of water must be raised. If it was not for friction it would be just as easy to raise 10 lbs. of water 10 feet high in a second, as to raise 100 lbs. 1-foot high. With the case of the small volume of water, the speed is ten times greater and, consequently, the friction is much greater. With the small pipe the pump plunger is brought suddenly against a column of water which must be started and moved at great speed, while with the large pipe the speed is only one-tenth as great. The shock to the pump and mill is, therefore, much less.

No pipe smaller than  $1\frac{1}{4}$  inch should ever be used in a well, and in deep wells it is more economical in the end, and certainly more satisfactory, to use tubular pumps having pipe larger than the cylinder so that the valves may be withdrawn without taking up the well pipe.

While many people make the mistake of using too small pipe, the error of using too large a cylinder is still more prevalent. With a large cylinder a mill can be made to do more work in high winds than it was intended to, but under the excessive strain both mill and pump are bound to wear out sooner, and the danger of a breakdown is largely increased. Any pump will raise water enough in a high wind, but high winds are rare. The most efficient pump is the one which operates easily, allowing the mill to run in the light breezes which are the prevailing winds. With a small cylinder and a large pipe the mill will run many more hours in a week and last many years longer. Neither suction nor discharge pipe should be smaller than one-half the diameter of the cylinder.

## **PUMPING CAPACITIES OF AERMOTORS**

Under ordinary conditions the actual quantity of water delivered will fall considerably below the theoretical capacity. Where the prevailing winds are light or variable, where the wind usually blows only a few hours each day, where the wind exposure is poor, or when it is desired to have the wheel run at less than its maximum speed, these conditions should be taken into consideration in determining the size of Aermotor needed to supply the required quantity of water.

With the vane spring set for maximum tension the 6-foot and 8-foot Aermotors are running at full speed will make about 32 strokes of the pump per minute; the 10-foot, 26 strokes; the 12-foot, 21 strokes; the 14-foot, 18 strokes and the 16-foot, 16 strokes. The smaller mills will attain this speed in winds blowing steadily from 15 to 18 miles per hour, and the larger ones in winds from 18 to 20 miles per hour when loaded according to the table.

The tension of the vane spring can be adjusted so that the maximum number of strokes will be about  $\frac{2}{3}$  of the figures given above, or any number of strokes between the two limits which may be desired.

Capacities shown in the "Aermotor Pumping Capacity" table are approximate, based on the mill set on the long stroke, operating in a 15 to 20 mile-an-hour wind. The short stroke increases elevation by one-third and reduces pump capacity one-fourth.

If wind velocity is 12-miles per hour, capacity is reduced approximately 22%; in 10-mile per hour wind, capacity reduces approximately 37%.

The pumping capacity of all Aermotors from 8-feet to 16-feet is the same with cylinders of the same diameter. This is because the length of stroke is increased in proportion to the size of the wheel. With the 6-foot mill, which is back-g geared more than the other sizes and has a stroke of only  $5\frac{1}{2}$  inches, the quantity of water delivered is about 30% less than for the other sizes. The reduction in capacity for any particular size of cylinder is compensated for in the ability of the 6-foot mill to raise water to a greater elevation than its true proportion. Pumps and cylinders used with the various sizes of mills should be capable of giving a clear stroke equal in inches to the diameter of the windwheel in feet; i.e., 8-inches for 8-foot, 10-inches for 10-foot, etc.

The capacities shown in the "pumping capacity" table are based on the long stroke of the mills. When the short stroke is used, the capacity should be reduced by about 25%. However, the same quantity of water may be obtained by using a cylinder of larger diameter so as to increase its capacity 25%. We do not advise using a windmill on the short stroke except where the pump already in the well has a cylinder which is so large as to overload the mill if operated on the long stroke.

The loads recommended in the table are for moderate wind conditions. In localities where the winds are strong, these loads may be considerably increased. To obtain the best results in light winds, the table should be closely followed.

A windmill should stand at least 15-feet above all obstructions within 400-feet.

Never use pipe smaller than the sizes for which our cylinders are fitted. For wells more than 100 feet deep, the best results are obtained by using Marcy or Ball Valve Cylinders with ash pump rod and pipe larger than the cylinder so that the plunger can be drawn up through it. In very deep wells it is advisable to use pipe enough larger than the cylinder so that a wood rod large enough to stand the heavy strain may be used.

To obtain the capacity of a pump with diameter of cylinder given in table, but with a longer stroke than 24 inches, add or multiply the capacity to represent the required length of stroke.

To obtain the amount of water discharged per minute, multiply the capacity per stroke by the number of strokes per minute. To obtain the amount of water discharged per hour, multiply this figure by 60.

### WATER DISCHARGED PER STROKE BY SINGLE ACTING CYLINDERS

Dia. of (Pump Cyl.) in In.	Length of Stroke in Inches with Capacity Per Stroke in Gallons												Area of Circle (Pump Cyl.) in Sq. Inches	Dia. of (Pump Cyl.) In In.
	1	2	3	4	5	6	7	8	10	12	18	24		
	1 3/8	.0064	.0128	.0192	.0256	.0320	.0384	.0448	.0512	.0640	.0768	.1152		
1 1/2	.0076	.0153	.0229	.0306	.0382	.0459	.0535	.0612	.0765	.0918	.1375	.1832	1.7671	1 1/2
1 5/8	.0090	.0180	.0270	.0360	.0450	.0540	.0630	.0720	.0900	.1080	.1620	.2140	2.0739	1 5/8
1 3/4	.0104	.0208	.0312	.0416	.0512	.0625	.0729	.0833	.1041	.1249	.1872	.2497	2.4053	1 3/4
1 13/16	.0112	.0224	.0336	.0448	.0560	.0672	.0784	.0896	.1120	.1344	.2016	.2688	2.5802	1 13/16
1 7/8	.0120	.0240	.0360	.0480	.0600	.0720	.0840	.0960	.1200	.1440	.2160	.2880	2.7612	1 7/8
1 31/32	.0132	.0263	.0395	.0527	.0659	.0790	.0922	.1054	.1317	.1580	.2371	.3161	3.0440	1 31/32
2	.0136	.0272	.0408	.0544	.0680	.0816	.0952	.1088	.1360	.1632	.2448	.3264	3.1416	2
2 3/16	.0163	.0325	.0488	.0650	.0812	.0976	.1137	.1300	.1625	.1952	.2928	.3904	3.7584	2 3/16
2 1/4	.0172	.0344	.0516	.0688	.0860	.1033	.1205	.1377	.1721	.2071	.3104	.4137	3.9760	2 1/4
2 1/2	.0212	.0425	.0637	.0850	.1062	.1275	.1487	.1700	.2125	.2550	.3825	.5100	4.9070	2 1/2
2 3/4	.0257	.0514	.0771	.1028	.1285	.1543	.1800	.2057	.2571	.3085	.4628	.6171	5.9395	2 3/4
3	.0306	.0612	.0918	.1224	.1530	.1836	.2142	.2448	.3060	.3672	.5508	.7344	7.0686	3
3 1/4	.0359	.0719	.1078	.1438	.1795	.2156	.2515	.2875	.3594	.4313	.6469	.8625	8.2957	3 1/4
3 1/2	.0416	.0833	.1249	.1666	.2082	.2499	.2915	.3332	.4165	.4998	.7497	.9996	9.6211	3 1/2
3 3/4	.0479	.0957	.1435	.1914	.2393	.2871	.3350	.3828	.4785	.5743	.8614	1.1485	11.044	3 3/4
4	.0544	.1088	.1632	.2176	.2720	.3264	.3808	.4352	.5440	.6528	.9792	1.3056	12.566	4
4 1/4	.0614	.1228	.1842	.2457	.3070	.3685	.4299	.4913	.6141	.7370	1.1054	1.4739	14.186	4 1/4
4 1/2	.0688	.1377	.2065	.2754	.3442	.4131	.4819	.5508	.6885	.8262	1.2393	1.6524	15.904	4 1/2
4 3/4	.0767	.1534	.2301	.3068	.3835	.4602	.5369	.6136	.7670	.9204	1.3806	1.8408	17.721	4 3/4
5	.0850	.1700	.2550	.3400	.4250	.5100	.5950	.6800	.8500	1.0200	1.5300	2.0400	19.635	5
5 1/2	.1028	.2057	.3085	.4114	.5142	.6171	.7199	.8228	1.0285	1.2342	1.8513	2.4684	23.758	5 1/2
5 3/4	.1124	.2248	.3372	.4496	.5620	.6744	.7868	.8992	1.1240	1.3488	2.0232	2.6975	25.967	5 3/4

Capacities are given in American Gallons

- Area of circle = diameter squared × .7854
- Circumference of a circle = diameter × 3.1416
- Pressure in pounds per square inch of a column of water = head in feet × .434
- Head in feet of a column of water = pressure in pounds per square inch × 2.30947
- A U.S. gallon = 231 cubic inches
- A U.S. gallon of fresh water weighs 8.33 pounds
- A U.S. gallon of sea water weighs 8.347 pounds
- A cubic foot of water (1728 cubic inches) contains 7.481 U.S. gallons and weighs 62.355 pounds
- Feet head × .434 = pounds pressure per square inch
- Pounds pressure × 2.31 = feet head
- Meters × 3.28 = feet head
- U.S. gallons × .833 = imperial gallons
- Imperial gallons × 1.2 = U.S. gallons
- Cubic feet × 7.48 = U.S. gallons
- To convert inches vacuum into feet suction, multiply by 1.13
- To reduce pounds pressure to feet head, multiply by 2.3
- To reduce heads in feet to pressure in pounds, multiply by .434
- Friction of liquid in pipes increases as the square of the velocity.

### Contents of Round Tanks in U.S. Gallons for Each Foot in Depth

Inside Diameter Ft.	Gallons One Foot In Depth	Inside Diameter Ft.	Gallons One Foot In Depth	Inside Diameter Ft.	Gallons One Foot In Depth	Inside Diameter Ft.	Gallons One Foot In Depth
1 0	5.87	5 9	194.19	10 6	653.69	15 3	1365.96
1 3	9.17	6 0	211.44	10 9	678.88	15 6	1407.51
1 6	13.21	6 3	229.43	11 0	710.69	15 9	1457.00
1 9	17.98	6 6	248.15	11 3	743.36	16 0	1503.62
2 0	23.49	6 9	267.61	11 6	776.77	16 3	1550.97
2 3	29.73	7 0	287.80	11 9	810.91	16 6	1599.06
2 6	36.70	7 3	308.72	12 0	848.18	16 9	1647.89
2 9	44.41	7 6	330.38	12 3	881.39	17 0	1697.45
3 0	52.86	7 9	352.76	12 6	917.73	17 3	1747.74
3 3	62.03	8 0	375.90	12 9	954.81	17 6	1798.76
3 6	73.15	8 3	399.76	13 0	992.62	17 9	1850.53
3 9	82.59	8 6	424.36	13 3	1031.17	18 0	1903.02
4 0	93.97	8 9	449.21	13 6	1070.45	18 3	1956.25
4 3	103.03	9 0	475.80	13 9	1108.06	18 6	2010.21
4 6	118.93	9 3	502.65	14 0	1151.21	18 9	2064.91
4 9	132.52	9 6	530.18	14 3	1192.69	19 0	2121.58
5 0	146.83	9 9	558.45	14 6	1234.91	19 3	2176.68
5 3	161.88	10 0	587.47	14 9	1277.86	19 6	2233.52
5 6	177.67	10 3	617.17	15 0	1321.54	20 0	2349.46

# SPECIFICATIONS FOR STANDARD "AMERICAN MADE" STEEL PIPE

(Inside) Nominal Size Inches	Actual Outside Diameter	Nominal Weight per Foot Pounds	Number Threads per Inch	Outside Diameter Pipe Coupling	(Inside) Nominal Size Inches	Actual Outside Diameter	Nominal Weight per Foot Pounds	Number Threads per Inch	Outside Diameter Pipe Coupling
1/8	.405	.24	27	41/64	2	2.37	3.65	11 1/2	2 1/2
1/4	.54	.42	18	23/32	2 1/2	2.87	5.79	8	3 3/32
3/8	.675	.56	18	57/64	3	3.5	7.57	8	4
1/2	.84	.85	14	1 1/16	3 1/2	4.0	9.10	8	4 17/32
3/4	1.05	1.13	14	1 1/4	4	4.5	10.79	8	5 1/16
1	1.315	1.67	11 1/2	1 43/64	5	5.56	14.61	8	6 1/4
1 1/4	1.66	2.27	11 1/2	2 1/32	6	6.62	18.97	8	7 1/16
1 1/2	1.9	2.71	11 1/2	2 11/32	8	8.62	28.55	8	9 3/8

## FRICTION OF WATER IN PIPES

Loss of Head in Feet Due to Friction, Per 100 Feet of Ordinary Iron Pipe  
(Based on Williams and Hazen Hydraulic Tables)

Gals Per Min.	1/4 Inch Pipe	3/8 Inch Pipe	1/2 Inch Pipe	3/4 Inch Pipe	1 Inch Pipe	1 1/4 Inch Pipe	1 1/2 Inch Pipe	2 Inch Pipe	2 1/2 Inch Pipe	3 Inch Pipe	4 Inch Pipe	5 Inch Pipe	6 Inch Pipe
	Fric.	Fric.	Fric.	Fric.	Fric.	Fric.	Fric.	Fric.	Fric.	Fric.	Fric.	Fric.	Fric.
1	28.0	6.4	2.1	1.9									
2	103.0	23.3	7.4										
3		49.01	15.8	4.1	1.26								
4		89.0	27.0	7.0	2.14	0.57	0.26						
5		126.0	41.0	10.5	3.25	0.84	0.40						
10			147.0	38.0	11.7	3.05	1.43	0.50	0.17	0.07			
15				80.0	25.0	6.50	3.0	1.08	0.36	0.15			
20				136.0	42.0	11.1	5.2	1.82	0.61	0.25			
25					64.0	16.6	7.8	2.73	0.92	0.38			
30					89.0	23.5	11.0	3.84	1.29	0.54			
35					119.0	31.2	14.7	5.1	1.72	0.71			
40					152.0	40.0	18.8	6.6	2.20	0.91	0.22		
45						50.0	23.2	8.2	2.80	1.15	0.28		
50						60.0	28.4	9.9	3.32	1.38	0.34	0.11	
70							113.0	53.0	18.4	6.21	2.57	0.63	0.21
75							60.0	20.9	7.1	3.05	0.73	0.24	0.13
100							102.0	35.8	12.0	4.96	1.22	0.41	0.16
120							143.0	50.0	16.8	7.0	1.71	0.58	0.23
125								54.0	18.2	7.6	1.86	0.64	0.30
150								76.0	25.5	10.5	2.55	0.88	0.39
175								102.0	33.8	14.0	3.44	1.18	0.48
200								129.0	43.1	17.8	4.40	1.48	0.62

### Friction of Water in 90° Elbows

Size of Elbow, Inches.....	1/2	3/4	1	1 1/4	1 1/2	2	2 1/2	3	4
Friction Equivalent Ft. Straight Pipe.....	5	6	6	8	7	8	11	15	16

### Pressure of Water Per Square Inch and Feet Head

Feet Head of Water and Equivalent Pressure					Lbs., Pressure and Equivalent Ft. Head of Water						
Feet Head	Lbs. per Sq. Inch	Feet Head	Lbs. per Sq. Inch	Feet Head	Lbs. per Sq. Inch	Lbs. per Sq. Inch	Feet Head	Lbs. per Sq. Inch	Feet Head	Lbs. per Sq. Inch	Feet Head
1	4.3	60	25.99	200	86.62	1	2.31	40	92.36	170	392.52
5	2.17	100	43.31	300	129.93	5	11.54	80	184.72	225	519.51
10	4.33	150	64.96	600	259.85	10	23.09	125	288.62	350	808.13
20	8.66	160	69.29	700	303.16	15	34.63	130	300.16	375	865.89
30	12.99	170	73.63	800	346.47	20	46.18	140	323.25	400	922.58
40	17.32	180	77.96	900	389.78	25	57.72	150	346.34	500	1154.48
50	21.65	190	82.29	1000	433.09	30	69.27	160	369.43	1000	2308.00

### Weight of Water Contained in One Foot Length of Pipe of Different Sizes

Size in	Pounds	Size in	Pounds	Size in	Pounds
1/2	.086	2	1.372	4	5.488
1	.343	2 1/2	2.159	4 1/2	6.966
1 1/4	.537	3	3.087	5	8.575
1 1/2	.774	3 1/2	4.214	6	12.348

Multiply by number of feet high or head

# FURLING OF THE WINDMILL WHEEL

This top view of windmill illustrates how the mill furls out of the high winds. You will note the wheel hub/shaft is offset from the mast pipe on which the mill revolves for directional changes of the wind direction. You will also note the tailbone is offset on the opposite side of the mast pipe and the vane spring holder is offset further beyond the tailbone.

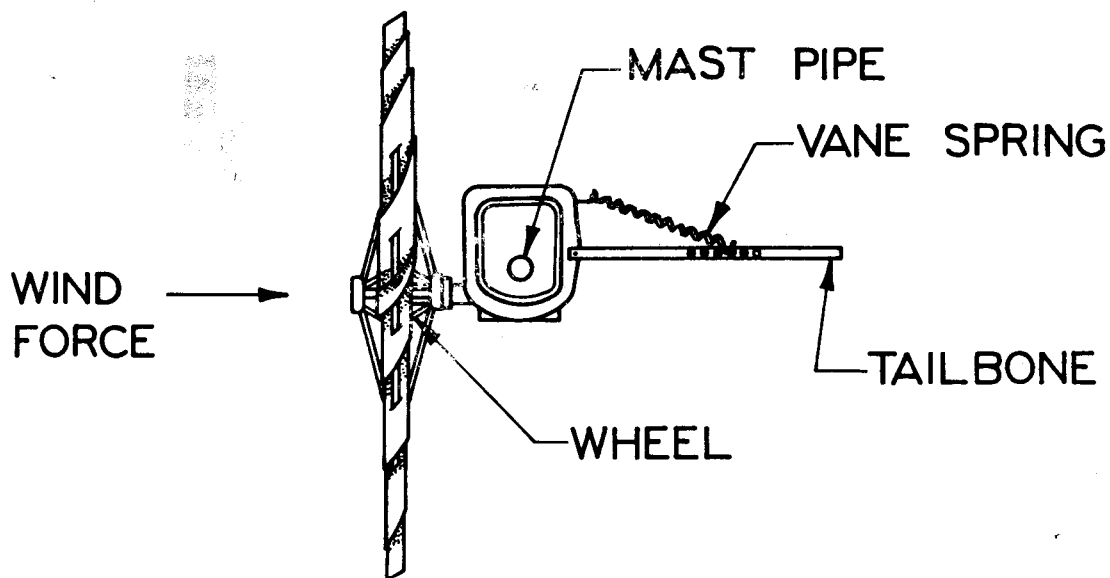

When the wind force increases sufficiently the force furls the mill counterclockwise, pivoting the mill on the mast pipe; whereas the tailbone is parallel to the true wind direction. The tension on the vane spring increases as the mill is furled and holds the mill into the wind. If the vane spring is connected to the outer hole in the tailbone, the tension is greater on the spring and therefore holds it into the wind at the higher wind velocities.

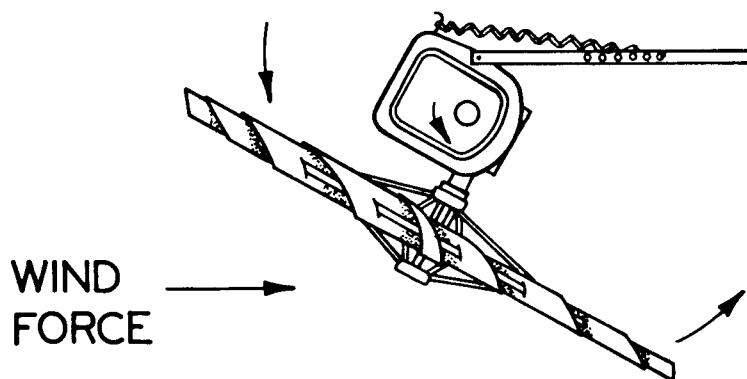

# INSTALLATION OF SUBMERSIBLE PUMP BELOW CYLINDER PUMP

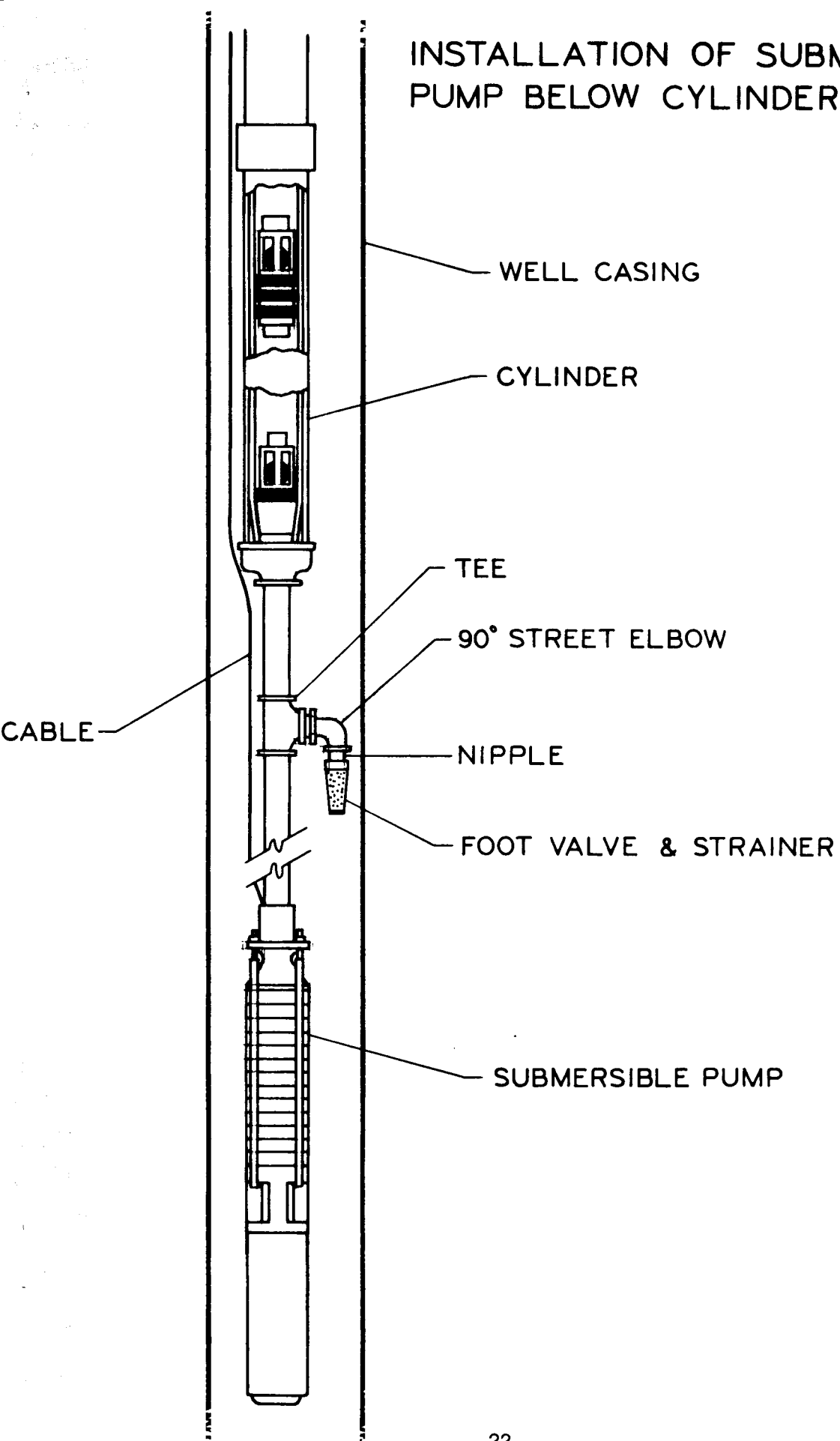

# **AERMOTOR WINDMILL CO., INC.**

1-800-854-1656

PHONE 325 / 651-4951

FAX 325 / 651-4948

Mail Address: P.O. BOX 5110

SAN ANGELO, TEXAS U.S.A. 76902

---

Shipping Address:

4277 Dan Hanks Lane

San Angelo, Texas

---

MONDAY through FRIDAY

8AM - 5PM C.S.T.

# **AERMOTOR WINDMILL CO., INC.**

1-800-854-1656

PHONE 325 / 651-4951

FAX 325 / 651-4948

Mail Address: P.O. BOX 5110

SAN ANGELO, TEXAS U.S.A. 76902

---

Shipping Address:

4277 Dan Hanks Lane

San Angelo, Texas

---

MONDAY through FRIDAY

8AM - 5PM C.S.T.